

	Refrigerated Air Dryer for High Temp.		Rev.	Date	Prepared By	Checked By	Approved By
			1	2020.09.18	WOO.I.H.	JO.S.J.	KIM.H.W.
	Air Cooled Type		2				
			3				
4							
Project Name		-	Model Name		HYD-800HT		
SPECIFICATION							
1							
2	Supply Voltage	380V	Inlet Flow Rate	120	Nm ³ /min		
3	Phase	3PH	Inlet Pressure	7	barg		
4	Frequency	60Hz	Inlet Temp.	45	°C		
5	Control use	220V	Outlet Flow Rate	120	Nm ³ /min		
6	Fulid	Compressed Air	Outlet Pressure	6.8	barg		
7	Location	Indoor	Outlet Temp.	33±5	°C		
8	Design Code	Maker STD.	Pressure Drop	0.2	bar		
9	Area Class	Non-Hazardous	Outlet Dew Point	2~10	°C		
10			Design Pressure	9.7	barg		
11			Design Temperature	70	°C		
12			Ambient Temperature	32	°C		
CONSTRUCTION							
13							
14	Refrigerant	R-22	Dryer Dimension (W x D x H)	1,500 X 1,900 X 2,150	mm		
15	Ref. Compressor Type	Scroll	Condenser (W x D x H)	2,400 X 920 X 995	mm		
16	Ref. Compressor Capacity	25 HP	Dryer Weight	1,250	kg		
17	Condenser Type	Remote, Air Cooled	Condenser Weight	250	kg		
18	Condenser Fan Motor	0.75 kW	Power Consumption	25.45	kW		
19		3 EA	Inlet Connection	200A	KS 10K SO.FF.		
20	Condenser Fan Size	630 mm	Outlet Connection	200A	KS 10K SO.FF.		
21	Condenser Capacity	25 HP	Drain Connection	15A	PT Female Screw		
22	Condenser Material	Aluminum & Copper	Color (Munsell)	5.7PB 4.1/9.9			
23	Heat Exchanger Type	Block		5.7PB 2.9/3.5			
24	Heat Exchanger Material	Aluminum					
25	Ref. Control Device	TEV					
26	Temp. Control Device	Hot Gas Bypass Valve					
27	Drain Trap Type	Level Sensor					
STANDRAD FEATURES AND CONTROL							
28							
29	Ref. Press. Transmitter	YES	Ref. Compressor	YES			
30	Ref. Liquid Filter Dryer	YES	Expansion Valve	YES			
31	Overload Relay	YES	Hot Gas Bypass Valve	YES			
32	PCB Controller	YES	Air Cooled Condenser	YES			
33	4.3" TFT LCD	YES	Accumulator	YES			
34	Air Pressure Gauge	YES	Liquid Ref. Receiver	YES			
35	Ref. Pressure Gauge	YES	Oil Separator	YES			
36	Dryer Start/Stop Switch	YES	Circuit Breaker	YES			
37	Moisture Indicator	YES	Ref. Compressor Heater	YES			
38	Drain	YES					
NOTES							
39							
40							
41							
42							
43							
44							
45							
46							

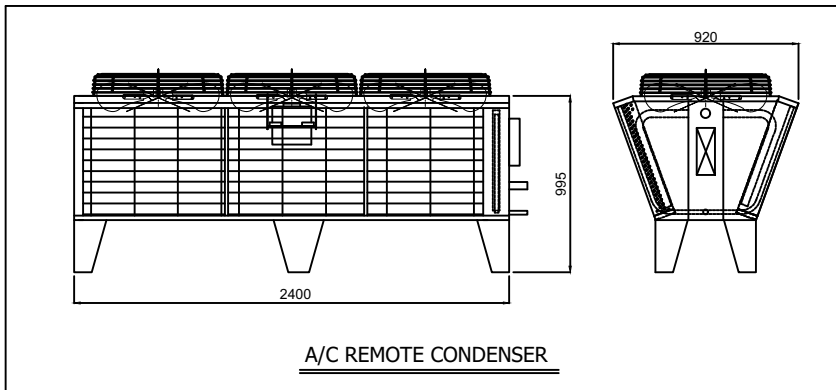

SPECIFICATION	
INLET AIR TEMPERATURE	45°C
AMBIENT TEMPERATURE	32°C
DEW POINT	2~10°C @ PDP
INLET AIR PRESSURE	7 barg
CAPACITY	120 Nm ³ /min
A/C REMOTE CONDENSER	25HP
DIMENSION(WXDXH, mm)	1,500 X 1,900 X 2150
DRYER / COND. WEIGHT	1,250 kg / 250kg
POWER CONSUMPTION	25.45 kW
POWER SUPPLY	380/440V - 3PH - 50/60HZ

NOZZLE		
N1	AIR INLET	200A KS10K SO.FF.
N2	AIR OUTLET	200A KS10K SO.FF.

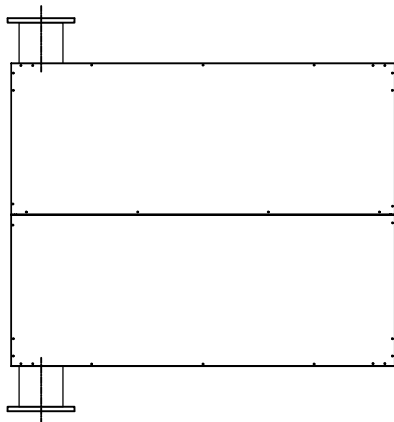
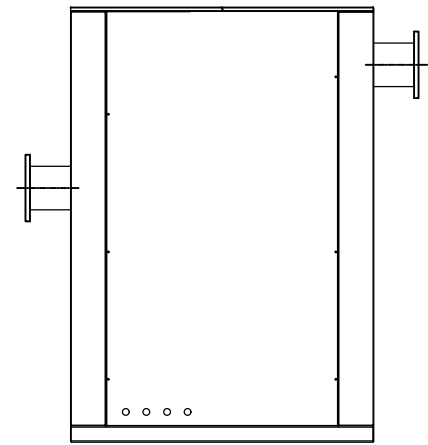
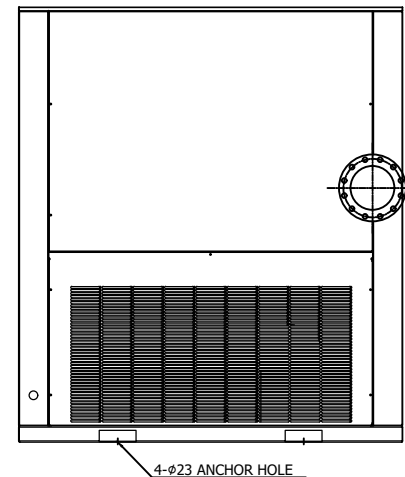
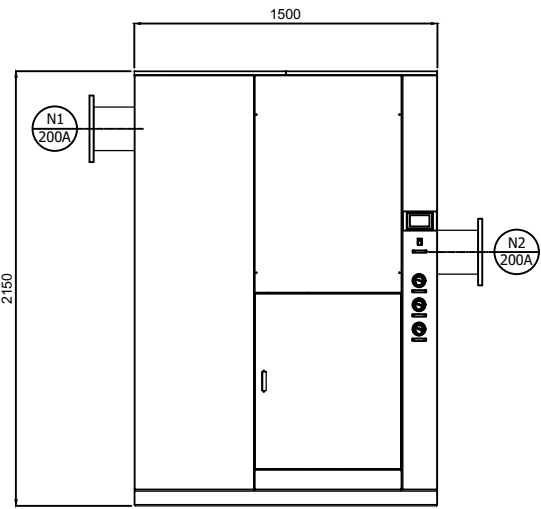
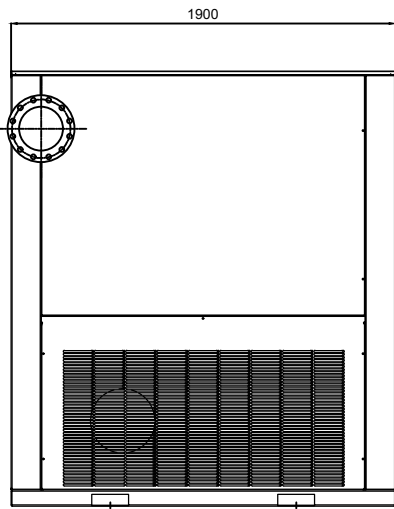

△												
△												
△												
△												
△	2020. 09. 18.	ISSUED FOR REFERENCE										
REV. NO.	DATE	DESCRIPTION	DWG	CHK	APPD	APPD	APPD	APPD	APPD	APPD	APPD	
PROJECT												
MANUFACTURER												
 GSA Global Services of America												
TITLE												
OUTLINE DRAWING												
ITEM NO.	HYD-800HT	DWG NO.	GSA-HYD-0800HT-01								REV.	△
SCALE	NONE											

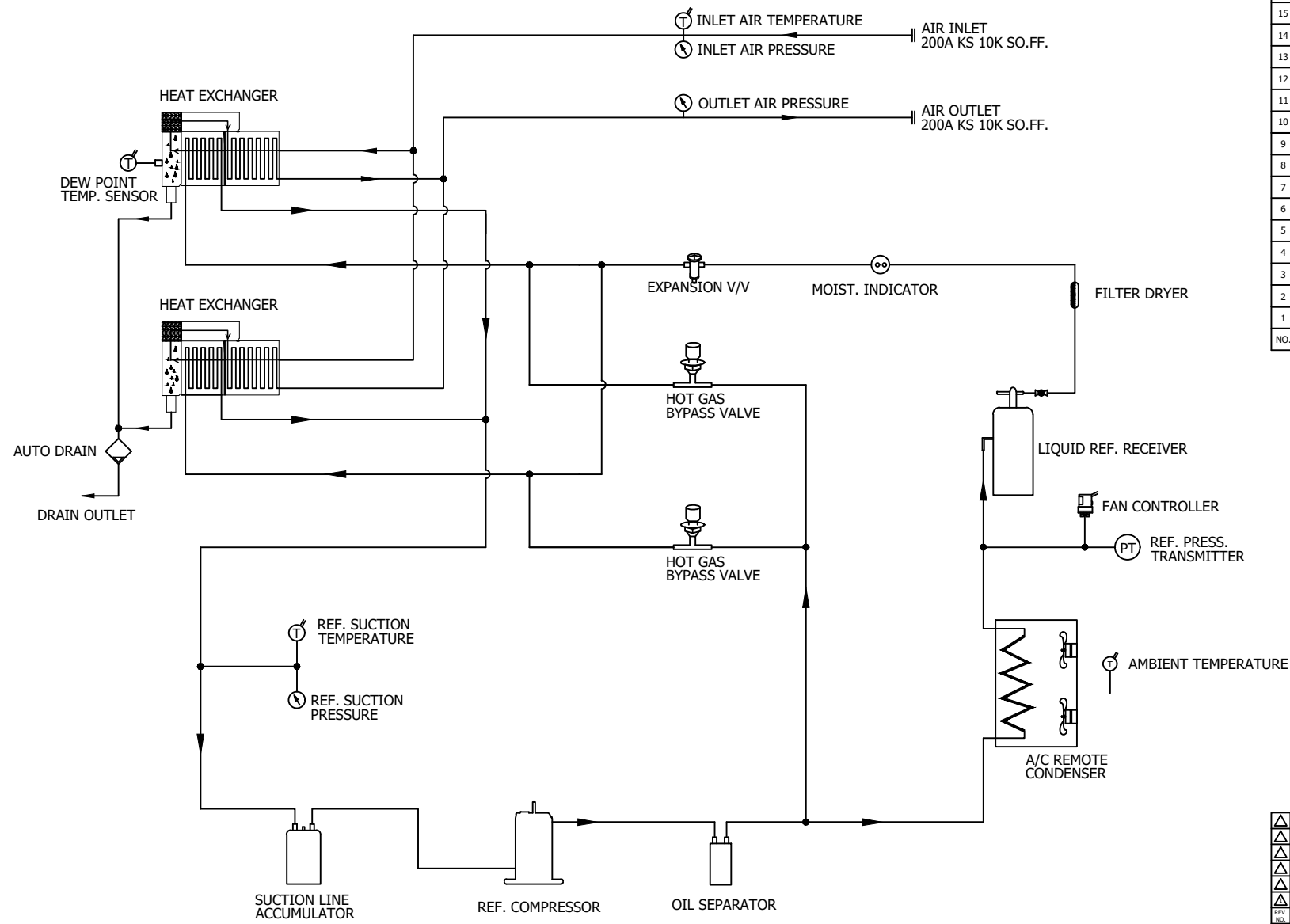

← AIR INLET LINE
 → AIR OUTLET LINE
 ← REF. LOW PRESS. LINE
 → REF. HIGH PRESS. LINE

DEW POINT	2~10°C @ PDP		
INLET AIR PRESSURE	7.0 barg		
INLET AIR TEMPERATURE	45°C		
CAPACITY	120 Nm ³ /min		
16	PRESS. GAUGE	OUTLET AIR	1
15	PRESS. GAUGE	INLET AIR	1
14	PRESS. GAUGE	REF. SUCTION	1
13	AUTO DRAIN	PT 15A	1
12	HGBV	-	2
11	ACCUMULATOR	-	1
10	HEAT EXCHANGER	400 HP	2
9	EXPANSION VALVE	25 TON	1
8	MOIST. INDICATOR	7/8"	1
7	FILTER DRYER	7/8"	1
6	REF. RECEIVER	-	1
5	FAN CONTROLLER	-	1
4	REF. PRESS. TRANSMIT.	-1 ~ 35 BAR	1
3	REMOTE CONDENSER	25 HP(COND. CAPACITY) (0.75kW, 8P, 630#, 3EA)	1
2	OIL SEPARATOR	-	1
1	REF. COMPRESSOR	25 HP (COOLING CAPACITY)	1
NO.	PART NAME	DESCRIPTION	QTY

△										
△										
△										
△										
△	2020. 09. 18.	ISSUED FOR REFERENCE								
REV. NO.	DATE	DESCRIPTION	ENG	CHK	APPD	APPD	APPD	APPD		
PROJECT										
MANUFACTURER										
 <small>Global Services of America</small>										
TITLE										
PIPING & INSTRUMENTATION DRAWING										
ITEM NO.	HYD-800HT	DWG NO.	GSA-HYD-0800HT-02							REV.
SCALE	NONE								△	

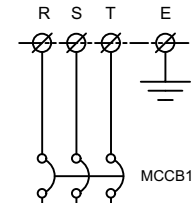

TR
380V 220V

CB1

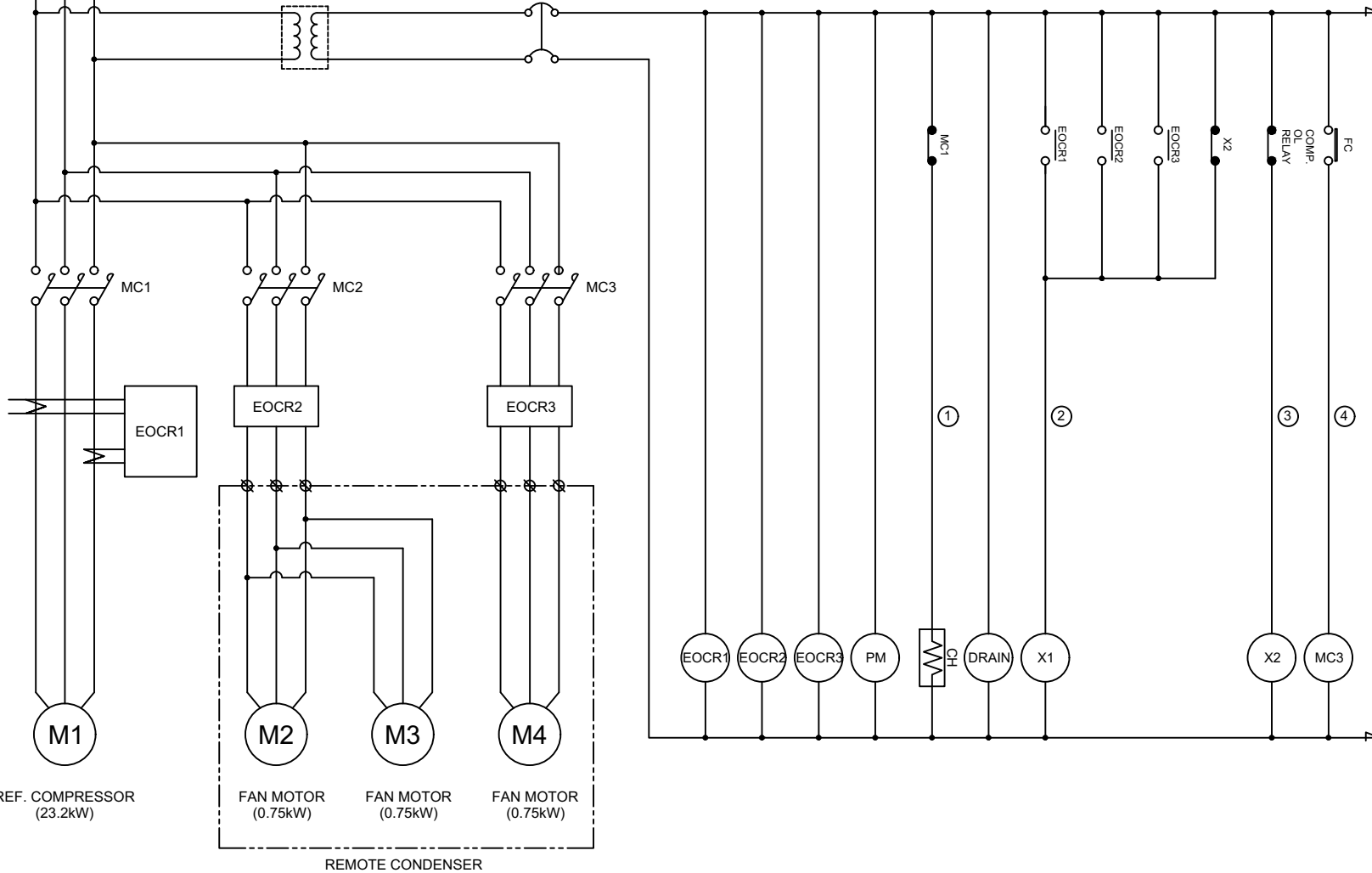

REF. COMPRESSOR
(23.2kW)

FAN MOTOR
(0.75kW)

FAN MOTOR
(0.75kW)

FAN MOTOR
(0.75kW)

REMOTE CONDENSER

POWER SOURCE AC 380/440V, 3Ph, 50/60Hz		
14	FC	FAN CONTROLLER
13	X1, X2	RELAY
12	DRAIN	CONDENSATE WATER DRAIN
11	CH	REF. COMP. HEATER
10	PM	REF. COMP. PROTECTION MODULE
9	CB1	CIRCUIT BREAKER
8	TR	TRANSFORMER
7	EOCR2, EOCR3	FAN MOTOR OVERLOAD RELAY
6	EOCR1	REF. COMP. OVERLOAD RELAY
5	MC2, MC3	FAN MOTOR MAGNETIC CONTACTOR
4	MC1	REF. COMP. MAGNETIC CONTACTOR
3	MCCB1	MOLDED CASE CIRCUIT BREAKER
2	M2, M3, M4	FAN MOTOR
1	M1	REF. COMPRESSOR
NO.	SYMBOL	DESCRIPTION

***REVERSE PHASE WARNING**

Be sure to check the rotation direction of the fan motor and the operating condition of the refrigerant compressor.

- The fan motor must rotate clockwise.
- When the refrigerant compressor is operating, the refrigerant suction pressure will be lowered.

When operating in reverse phase, the refrigerant compressor is damaged.

In case of reverse phase, change the position of 2 wires out of 3 wires of the power supply line.

Problems caused by incorrect power connection are not guaranteed.

△									
△									
△									
△									
△									
REV. NO.	2020. 09. 18.	ISSUED FOR REFERENCE							
DATE		DESCRIPTION	DWG	CHK	APPD	APPD	APPD	APPD	APPD

MANUFACTURER
GSA
Global Service Air & Gas

TITLE
WIRING DRAWING

ITEM NO.	HYD-800HT	DWG NO.	GSA-HYD-0800HT-03_01	REV.	△
SCALE	NONE				

FROM
GSA-HYD-0800HT-03_01

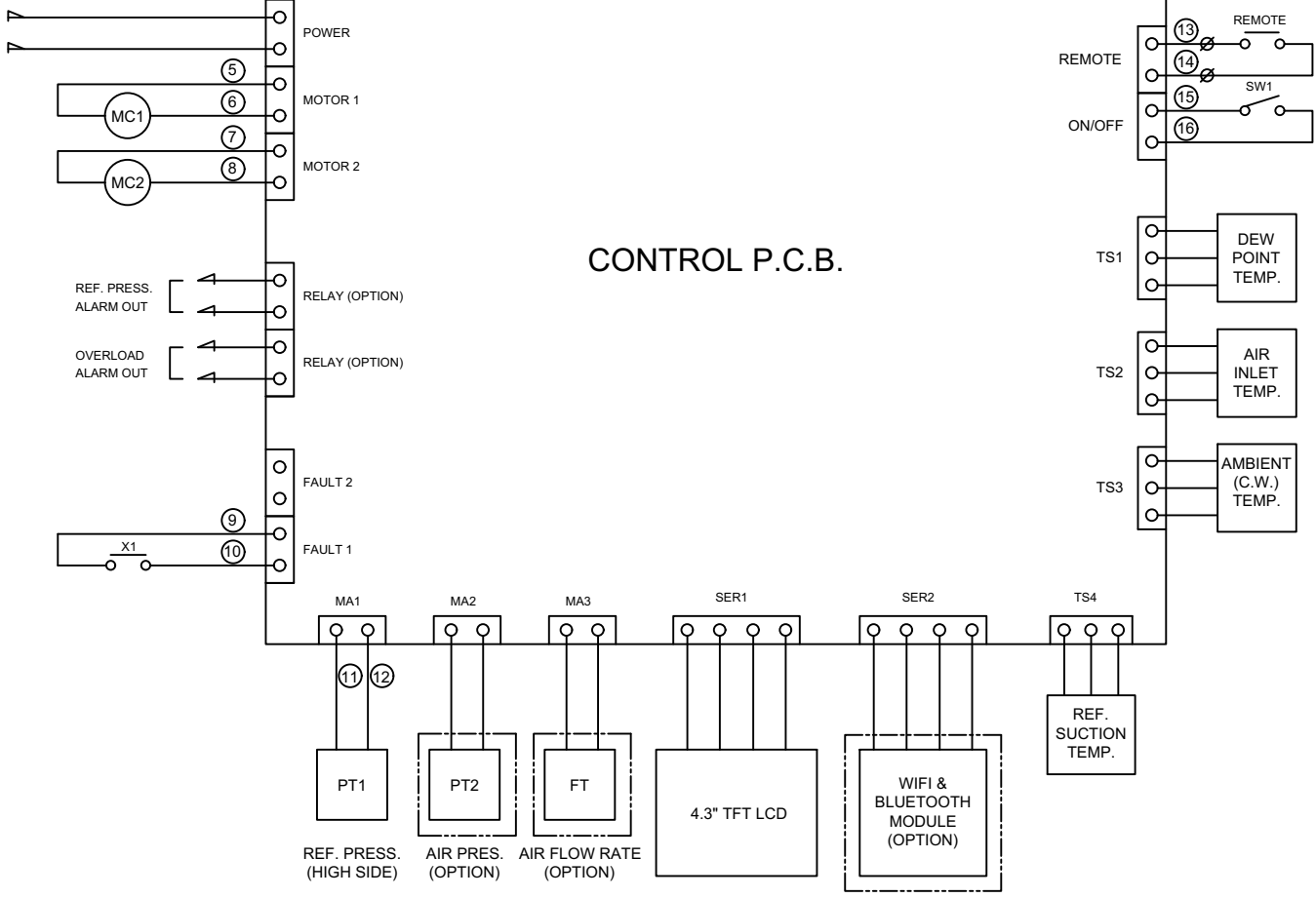

CONTROL P.C.B.

POWER SOURCE AC 380/440V, 3Ph, 50/60Hz		
14	FC	FAN CONTROLLER
13	X1, X2	RELAY
12	DRAIN	CONDENSATE WATER DRAIN
11	CH	REF. COMP. HEATER
10	PM	REF. COMP. PROTECTION MODULE
9	CB1	CIRCUIT BREAKER
8	TR	TRANSFORMER
7	EOCR2, EOCR3	FAN MOTOR OVERLOAD RELAY
6	EOCR1	REF. COMP. OVERLOAD RELAY
5	MC2, MC3	FAN MOTOR MAGNETIC CONTACTOR
4	MC1	REF. COMP. MAGNETIC CONTACTOR
3	MCCB1	MOLDED CASE CIRCUIT BREAKER
2	M2, M3, M4	FAN MOTOR
1	M1	REF. COMPRESSOR
NO.	SYMBOL	DESCRIPTION

***REVERSE PHASE WARNING**

Be sure to check the rotation direction of the fan motor and the operating condition of the refrigerant compressor.

- The fan motor must rotate clockwise.
- When the refrigerant compressor is operating, the refrigerant suction pressure will be lowered.

When operating in reverse phase, the refrigerant compressor is damaged.

In case of reverse phase, change the position of 2 wires out of 3 wires of the power supply line.

Problems caused by incorrect power connection are not guaranteed.

REV. NO.	DATE	DESCRIPTION	ENG	CHK	APPD	APPD	APPD
2020.09.18.		ISSUED FOR REFERENCE					

PROJECT: _____

MANUFACTURER: **GSA**
Global Services of America

TITLE: **WIRING DRAWING**

ITEM NO.	HYD-800HT	DWG NO.	GSA-HYD-0800HT-03_02	REV.	△
SCALE	NONE				