



N<sub>2</sub>, O<sub>2</sub>, H<sub>2</sub>,  
Ar., CH<sub>4</sub>, Co.,  
Co<sub>2</sub>, PSA



Water Chiller



Drain Valve



Air Filter



Aftercooler



Refrigerated  
/ Dessiccant /  
Membrane  
Air Dryer



# Compressed Air Filter

Top-Quality / Eco-Friendly

[www.gsadyer.com](http://www.gsadyer.com) [gsa@gsadyer.com](mailto:gsa@gsadyer.com)

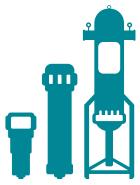

## Why Compressed Air Filter?

Purification of air we breathe carries contaminants. Airborne particles, water, microbes, and chemical gases enter compressors. At a state these contaminants become concentrated and more destructive. In the compressed air system, hard particles assault equipment and piping. The result is damage to the system and more particles generated. Since the compressed air is heated during the compression aftercooler is then used to remove the heat of compression.

During this stage a significant quantity of liquid at compressor delivering 100 scfm (2.8 m<sup>3</sup>/hr) at 100 psig (7 bar) and 100 °F (38°C) can produce 18 gallons (68 liters) of water a day. These liquids, if not removed, will cause erosion, damage to pneumatic equipment and instruments. Filtering and drying processes remove particles, moisture, microbes, and chemicals from compressed air. Clean, dry air protects the air system, reduces maintenance costs and increases finished products yields.



Painting ▲



Filter Element ▲

## How it works?

Particles traveling in a fluid have a mass and velocity. The fluid will follow the path of least resistance. Some particles will impact onto the filter medium and be caught due to their inertia driving them into the filter. Extremely small particles will bounce around randomly in a gas stream as they strike liquid or gas molecules. The random path of the particles increases the chance it will strike the compressed air filter and be captured. If the particle is larger than the pore of the filter, it is retained. The pores can be infinitely smaller, and there can be layer after layer of media for the liquid/gas to pass through. Direct interception is the most common form of retention in both gas and liquid service. Our filters maximize their direct interception with torturous flow paths, which increase the filter's retention capability.

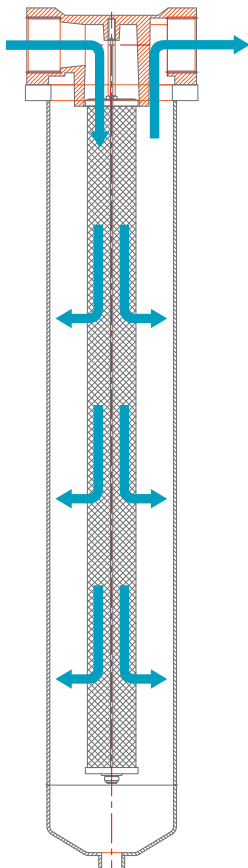

Air Filter Type (Possible : ○, Optimum : ●)

Type		Particulate Filter	Coalescing Filter	Carbon Filter
Moisture	Condensate	○	○	
	Aerosol		●	
Oil	Condensate oil	●		
	Aerosol		●	
	Oil vapor			●
Particle	Scale / Dirt	●		

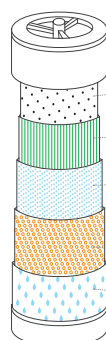

### Element Structure

- 1<sup>st</sup> layer**  
Coal-laced porous filter 3µm.
- 2<sup>nd</sup> layer**  
Microfiber filter for removing oil.
- 3<sup>rd</sup> layer**  
One out of three kinds (1ppm, 0.1ppm, 0.01ppm).  
Ultrafine micro filter for removing oil and water in compressed air or chemical gases.
- 4<sup>th</sup> layer**  
Coal-laced porous filter 60µm.
- 5<sup>th</sup> layer**  
Water-repellent drain layer.



## Why GSA Compressed Air Filter?

- 1 Pressure Gauge**
  - It helps us to recognize the contamination of filter element.
- 2 Element**
  - Various filter elements are put into filter housing.
  - 40 $\mu$ m, 5 $\mu$ m, 1ppm, 0.1/0.01/0.003ppm.
  - Remove particles, moisture, microbes and chemicals from compressed air.
- 3 Drain Valve**
  - No-loss drain valve / Timer controlled drain valve.
  - Discharging condensate.
- 4 Powder Coating**
  - The coating is applied electrostatically and is then cured under heat to allow it to flow and form a "skin". It creates a hard finish that is tougher than conventional paint.
  - The powder coating can produce much thicker coatings than conventional liquid coatings without running or sagging. Applied to HYF-15A~50A.
- 5 Drain Float**
  - Float type and discharging the condensate.
  - Applied to HYF-15A~20A.
- 6 Filter Leg**
  - Support filter body.
  - HYF-125A and above.

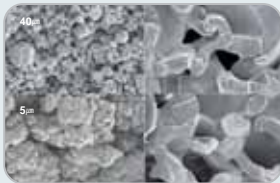

### 40 $\mu$ m, 5 $\mu$ m Element

- Higher filtering efficiency than other brands because its crystalloid is very fine.

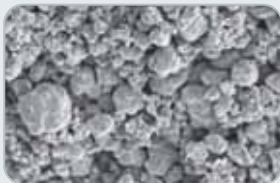

### Equalized Granularity

- Filter element, densely equalized granularity, approved as a food wrapping material by FDA.

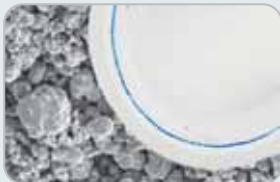

### Removing Oil Vapor

- Our 5 $\mu$ m filter element can remove oil vapor too.



### Cyclone Effect

- The particles and heavy moisture can be effectively separated by cyclone effect of upper module plate.
- Anti-vibration guide bar at the bottom prevents condensate from being carried over.



### Multilayer Filter Element

- Particles and oil vapor can be removed simultaneously by multilayer filter element.



### Vent Cock

- Easy to release internal pressure.
- Easy to check float and to remove condensate.
- Applied to HYF-15A~20A models.



Upgrade your compressed air treatment system with GSA's aftercoolers, refrigerated air dryers, adsorption dryers, drains, filters, chillers and PSA system.



# Technical Specifications

Model	Particle Removal	Max. oil Carryover at 20°C	Max. Temperature °C	Pressure drop (bar)		Differential pressure for element change			Element Color	Material	
				dry	wet	bar	psi	month			
H	40	40 Micron	-	79	0.05	0.15	0.4	5.8	6	White	Polyethylene
	5	5 Micron	-		0.05	0.15				White	Polyethylene
Y	1	1 Micron	1 ppm		0.15	0.3				Red	Borosilicate
	0.1	1 Micron	0.1 ppm		0.15	0.3				White	Borosilicate
E	0.01	1 Micron	0.01 ppm		0.15	0.3				Yellow	Borosilicate
	0.01F -0.003	-	0.003 ppm		0.1	0.2				White	Activated Carbon

Model	Flow Rate		Max. Pre. bar	Connection inch	Element Q'ty EA	Dimension (W x H) mm	Weight kg
	Nm <sup>3</sup> /min	scfm					
H	15A	1	35	1/2	1	105 x 270	1.5
	20A	1.9	67	3/4	1	105 x 310	1.5
	25A	3.4	120	1	1	105 x 435	1.9
	40A	10	353	1 1/2	1	144 x 700	12
	50A	14	494	2	1	185 x 930	21
	65A	28	989	2 1/2	2	550 x 1105	88
Y	80A	42	1483	3	3	550 x 1105	103
	100A	70	2472	4	5	600 x 1125	120
F	125A	84	2996	5	6	700 x 1195	170
	150A	112	3955	6	8	700 x 1195	180
	200A	196	6922	8	11	1000 x 2367	300
	250A	330	11654	10	19	1200 x 2745	400
	300A	504	17799	12	30	1400 x 2745	500

Model	Flow Rate		Max. Pre. bar	Connection inch	Element Q'ty EA	Dimension (W x H) mm	Weight kg
	Nm <sup>3</sup> /min	scfm					
H	15A	1	35	1/2	1	106 x 340	17
Y	20A	1.9	67	3/4	1	106 x 390	19
	25A	3.4	120	1	1	106 x 510	21
/	40A	10	353	1 1/2	1	144 x 700	25
	50A	14	494	2	1	185 x 925	28

- \*Notes**
- Operating Pressure : 7bar
  - Design Pressure : 9.7bar
  - Working Temperature : 40 / 5µm ----- Max. 65°C  
1 / 0.1 / 0.01 / 0.01F ----- Max. 54°C
  - Stainless steel material filter is also available upon request.
  - Filter leg is standard from HYF-125A and above.
  - Our filter element model name is HYE  
ex) **HYF-40-15A**    **HYE-40-15A**
  - HYE-50A is commonly used for HYF-50A filters and above.

All specification can be changed to improve the quality without notice.

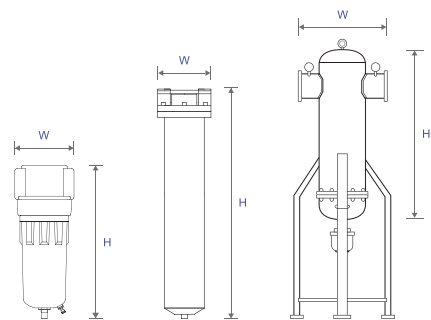

**GSA Co., Ltd.**

169-18, Yongsu-Gil, Chowol-eup, Gwangju-si, Gyeonggi-do, Korea

Tel. +82-31-798-0171~4 Fax. +82-31-798-0178

[www.gsadyer.com](http://www.gsadyer.com)    [gsa@gsadyer.com](mailto:gsa@gsadyer.com)